



# SERHIDRA S.A.S

Minería y Construcción



**SERHIDRA S.A.S**  
Minería y Construcción

[www.serhidra.com](http://www.serhidra.com)

## Contáctanos



**Dirección:**

Parque empresarial Santo Domingo Manzana B  
Bodega 17 Mosquera – Cundinamarca



**Celular:**

315 356 22 62 - 318 291 74 77



**Correo:**

administracion@serhidra.com

## CONTENIDO:

<b>Modelo Martillo</b>	<b>Pagina</b>
Atlas Copco .....	<a href="#">4</a>
Bobcat .....	<a href="#">5</a>
Caterpillar .....	<a href="#">5</a>
Doosan .....	<a href="#">6</a>
Everdigm .....	<a href="#">6</a>
Furukawa .....	<a href="#">7</a>
Indeco .....	<a href="#">9</a>
Komac .....	<a href="#">10</a>
Krupp .....	<a href="#">12</a>
Montabert .....	<a href="#">12</a>
NPK .....	<a href="#">13</a>
Okada .....	<a href="#">14</a>
Rammer .....	<a href="#">14</a>
Sandvik .....	<a href="#">14</a>
Soosan .....	<a href="#">15</a>
Stanley .....	<a href="#">16</a>
Torpedo .....	<a href="#">16</a>

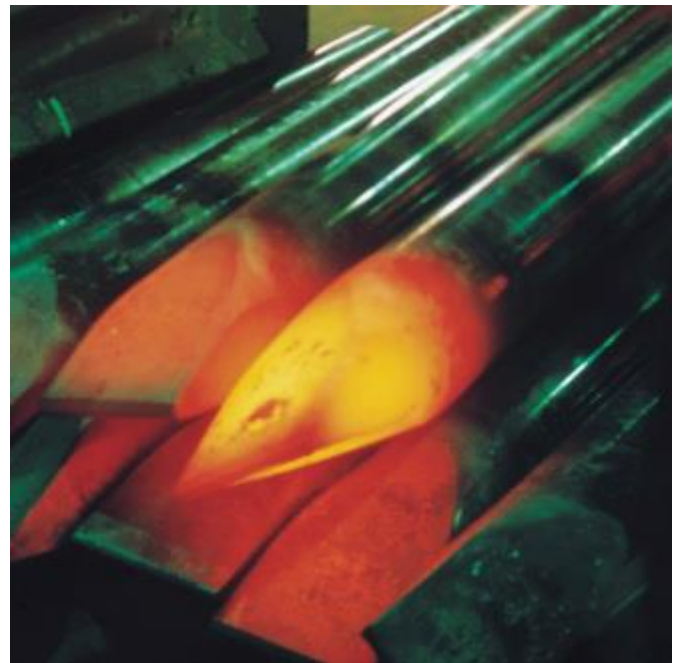
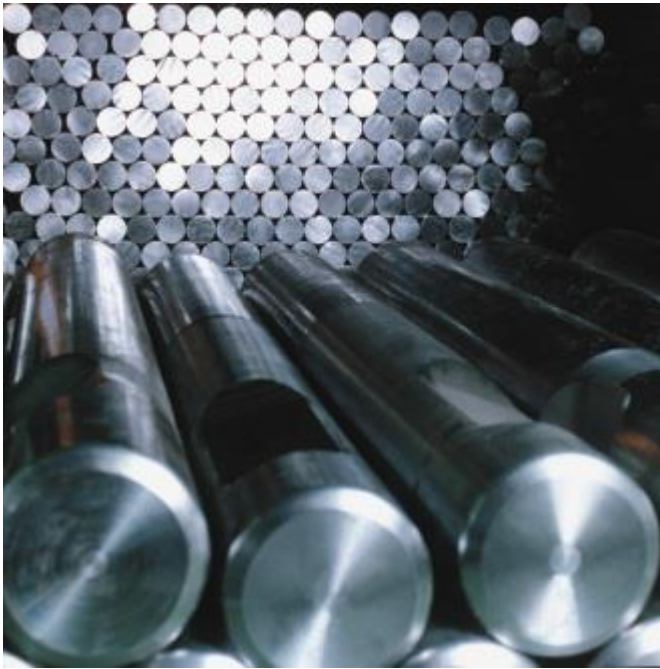

---



## CONSEJOS PRÁCTICOS PARA EL USO DE HERRAMIENTAS DE DEMOLICIÓN PESADA

Se define como vida útil de la punta al tiempo en que la herramienta demora en desgastarse completamente hasta que el lado de impacto está completamente consumido, este desgaste puede expresarse en horas, días o meses. Sin embargo, sólo tiene sentido utilizar este método de comparación, si las condiciones de uso se mantienen constantes. Si el material que se rompe no es el mismo y varía la frecuencia de percusión, esto produce diferencias estándar en una proporción de 1: 100 con herramientas equivalentes.

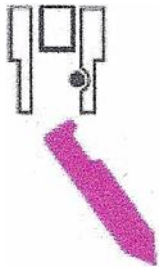
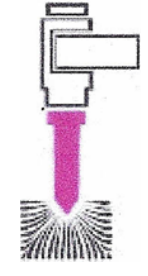
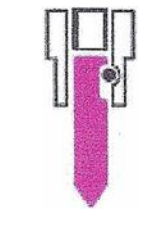
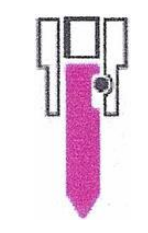
Así se consigue la máxima funcionalidad, seguridad y fiabilidad de las puntas:

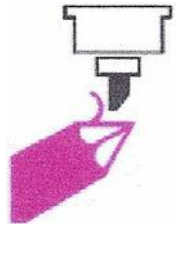
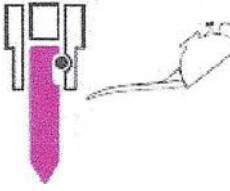
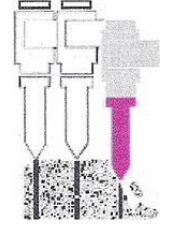
	<p>Aplique grasa de alta resistencia, especial para punteros, antes de montar la herramienta en el martillo.</p>		<p>Operar su martillo sólo después de haber colocado la herramienta en posición de demolición sobre la superficie de trabajo. Deje de golpear inmediatamente cuando el material se rompa.</p>
	<p>Evite demasiado juego entre los bujes y la herramienta para evitar rotura de la herramienta o daños en los bujes y el pistón.</p>		<p>No se debe trabajar más de 10 segundos en el mismo punto, si el material se resiste a la demolición buscar otro punto de ataque. ¡Evitar la percusión en vacío! Al calentarse el puntero se debe dejar enfriar al aire.</p>
	<p>La posición correcta del trabajo debería ser vertical o en un ángulo de 90° hacia el nivel del trabajo. La herramienta el martillo y la maquina portante deben formar una unidad.</p>		<p>Reacondicionamiento de herramientas, herramientas sin filo o bordes dañados, pueden ser reacondicionadas con fresado, cepillado o torneado.</p>
	<p>Lubricación: Engrase por lo menos 4 veces al día para asegurarse de que la película lubricante no se rompa.</p>		<p>Utilice un enfoque gradual a la ruptura material, sección por sección. Comience por la zona más débil de la pieza, y luego trabaje en dirección al centro.</p>

Serhidra SAS no se responsabiliza por rupturas por violencia a causa de no observar las instrucciones de lubricación y mantenimiento. También las causas de rupturas se pueden detectar correctamente a través de los análisis correspondientes

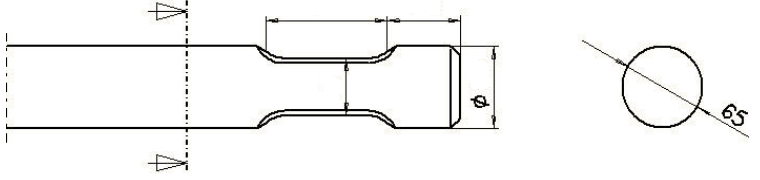
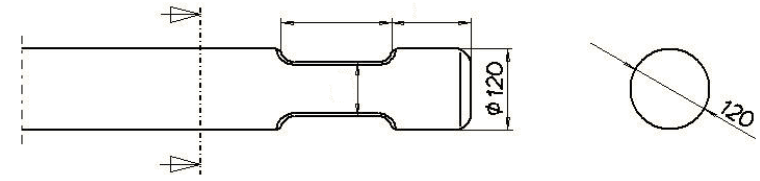
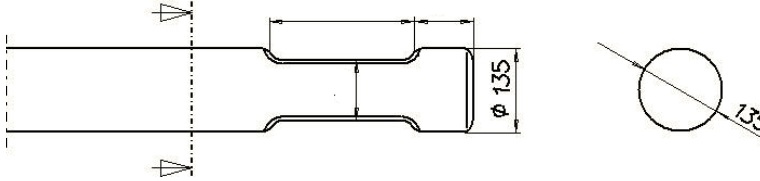
MODELO MARTILLO	DIAGRAMA	LONG (mm)	PESO (kg)
Atlas Copco SB 200		800	19
Atlas Copco MB 1200		1100	87
Atlas Copco MB 1600		1100	107

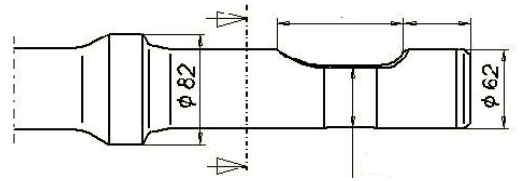
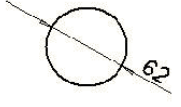
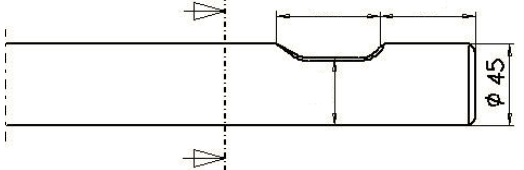
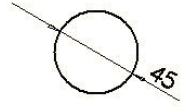
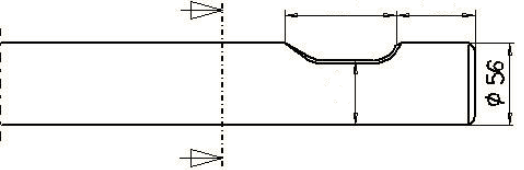
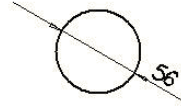
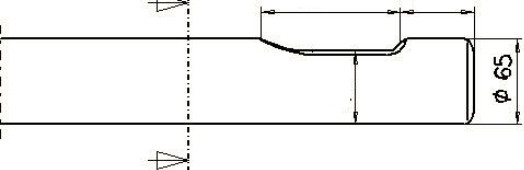
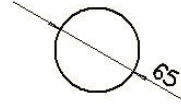
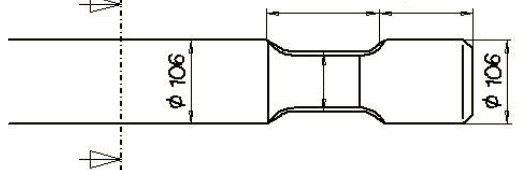
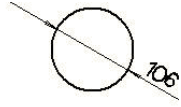
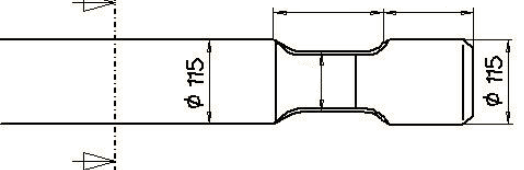
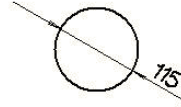
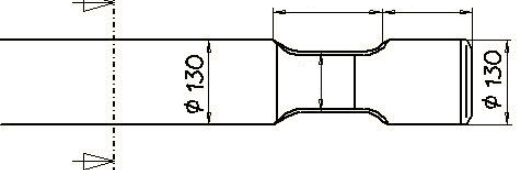
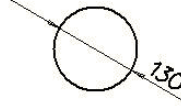
Bobcat HB 880			600	14
Bobcat 1750			480	6
Caterpillar H 55			580	11
Caterpillar H 65			700	17
Caterpillar H 115			1050	65
Caterpillar H 120			1060	77
Caterpillar H 130			1100	101

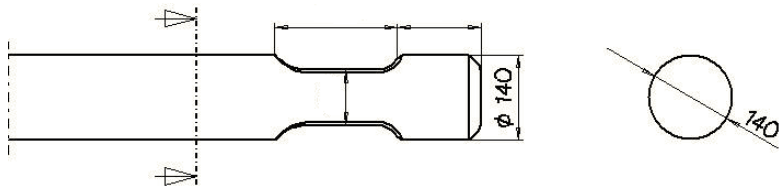
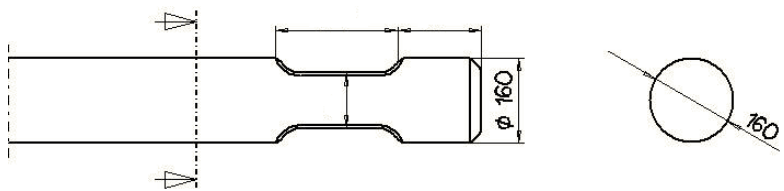
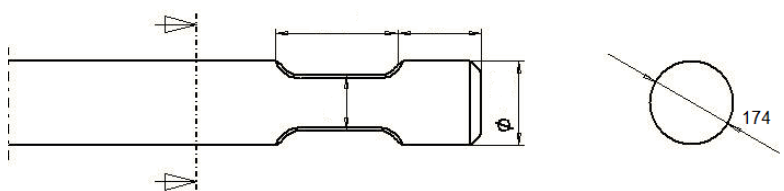
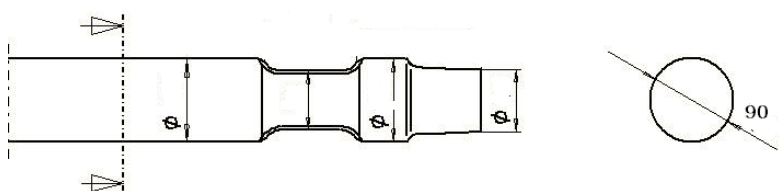
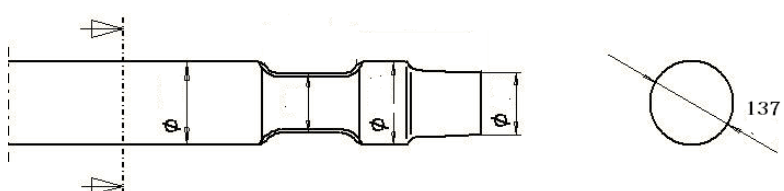
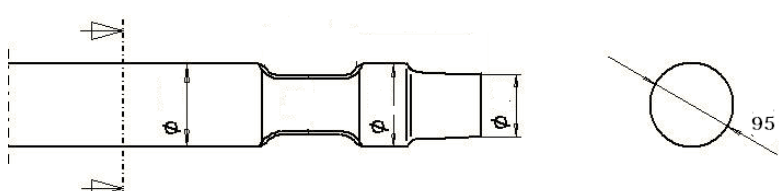
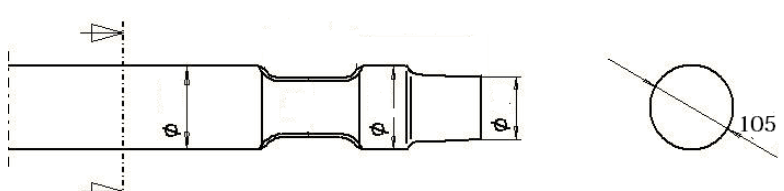
Caterpillar H140		1200	128
Caterpillar H 160		1300	183
Caterpillar H 180 DS		1450	247
Doosan DXB 90			
Doosan DXB 170		1420	170
Everdigm EHB 10		900	43
Everdigm EHB 13		1050	62

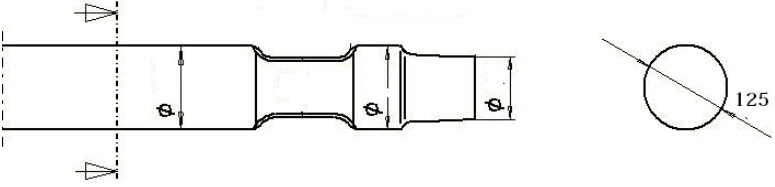
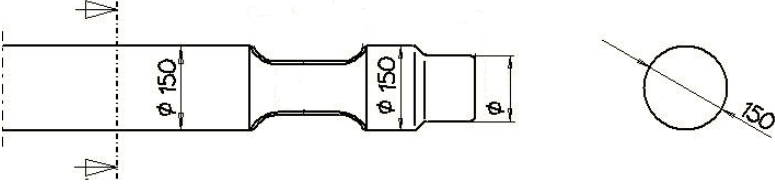
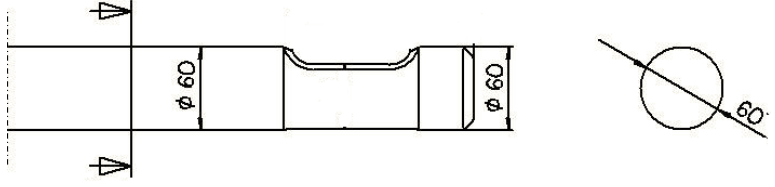
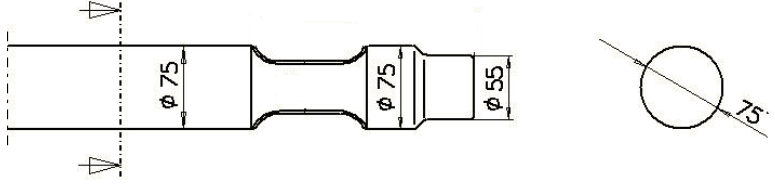
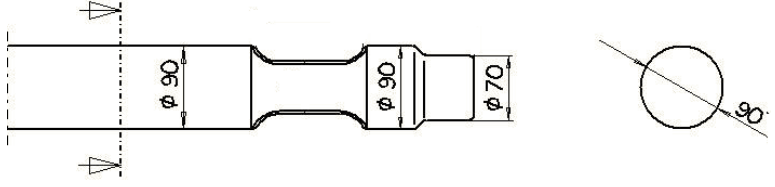
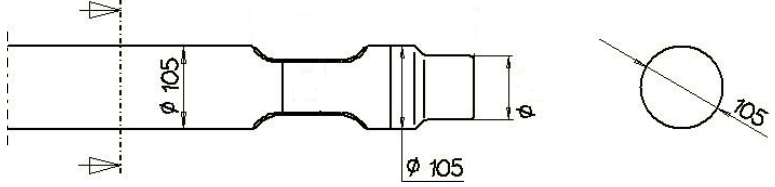
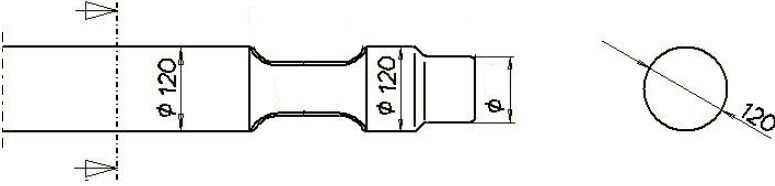
<p>Everdigm EHB 20</p>			
<p>Everdigm EHB 30</p>			
<p>Furukawa F 4</p>		<p>540</p>	<p>11</p>
<p>Furukawa F 6</p>		<p>720</p>	<p>20</p>
<p>Furukawa F 9</p>		<p>800</p>	<p>33</p>
<p>Furukawa F 12</p>		<p>1050</p>	<p>62</p>
<p>Furukawa F 19</p>		<p>100</p>	<p>84</p>



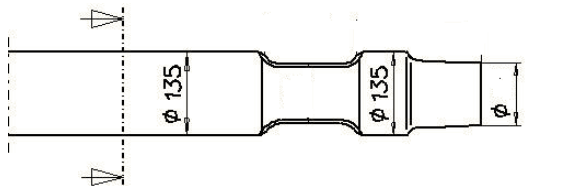
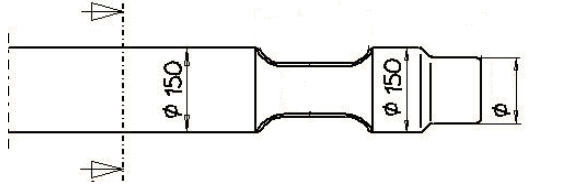
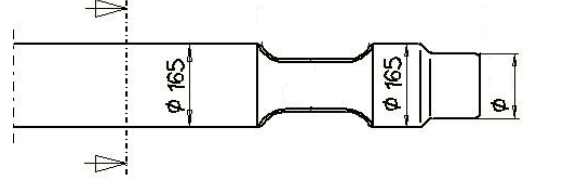
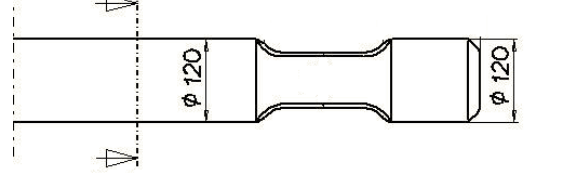
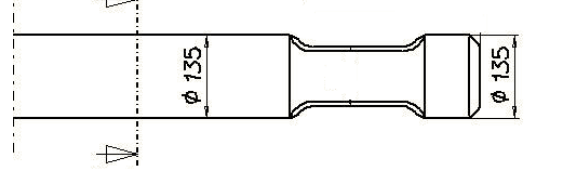
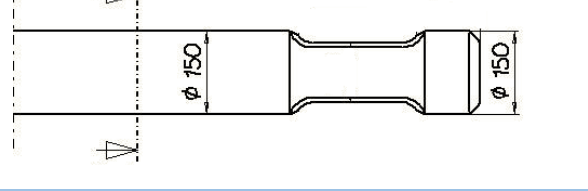
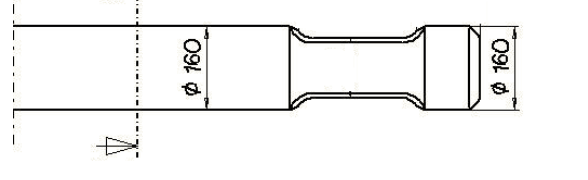

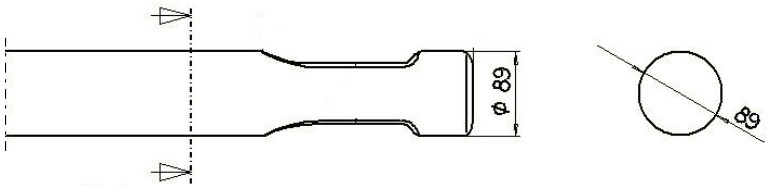
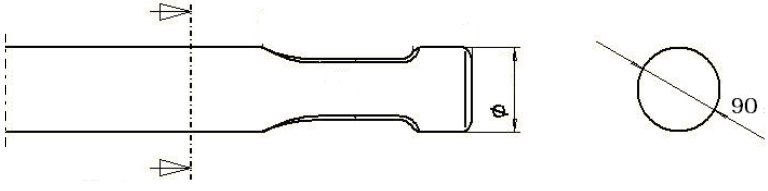
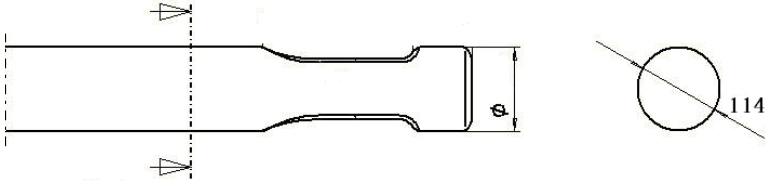
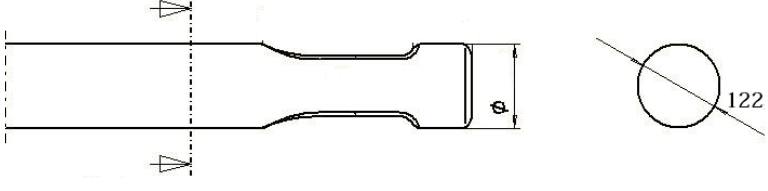
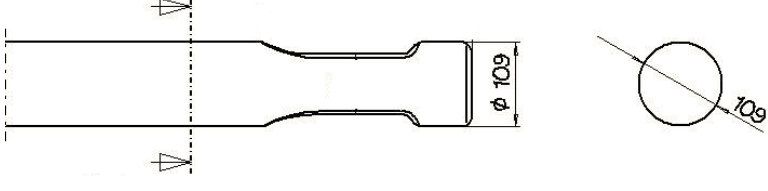
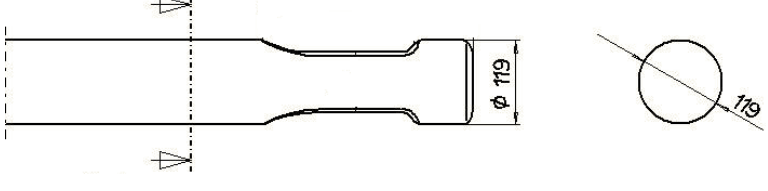
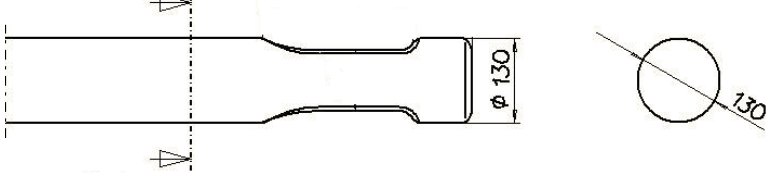

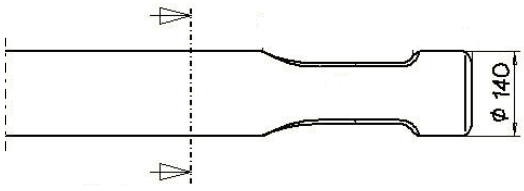
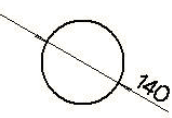
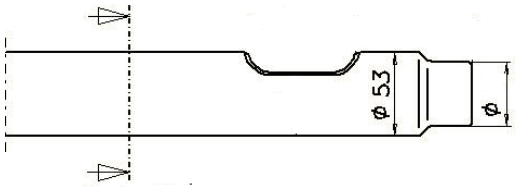
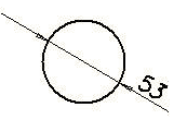
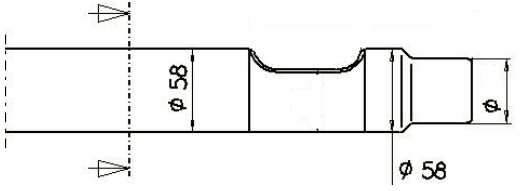
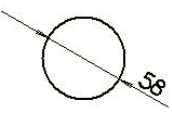
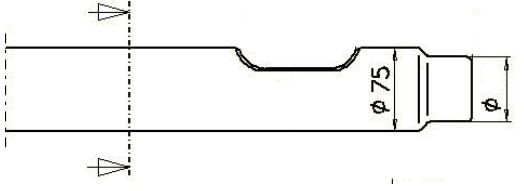
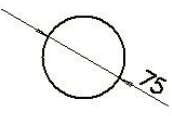
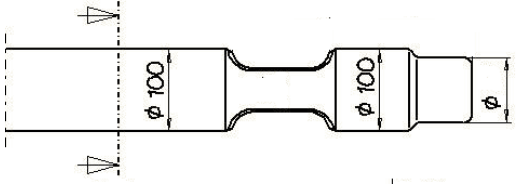
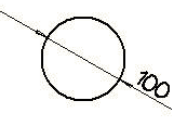
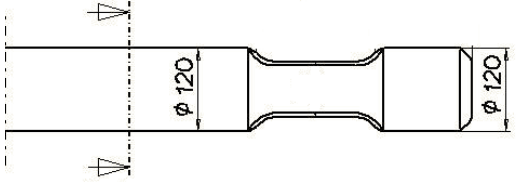
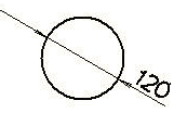
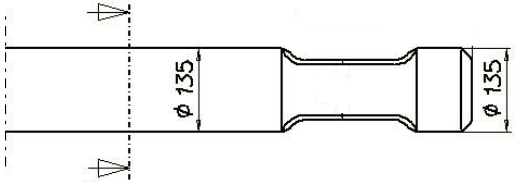
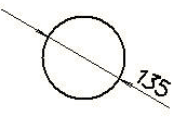

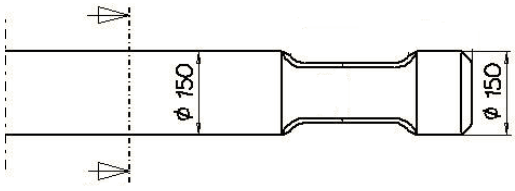
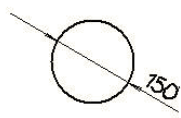
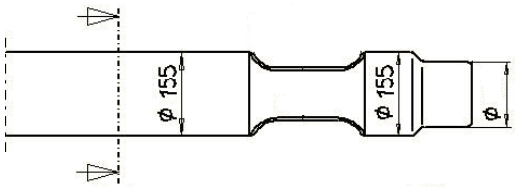
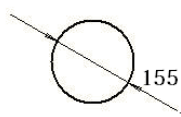
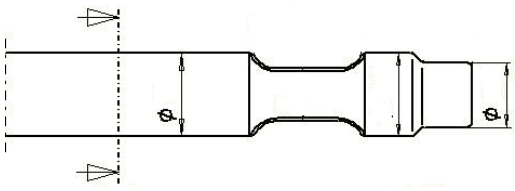
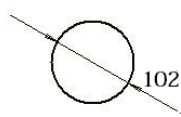
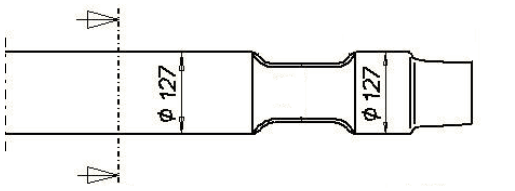
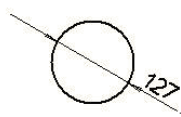
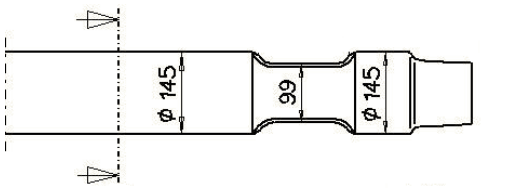
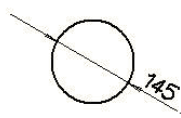
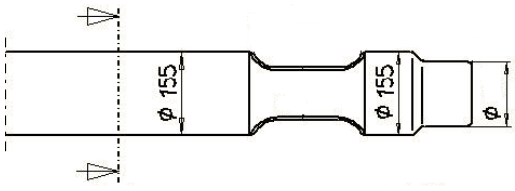
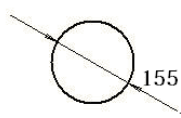
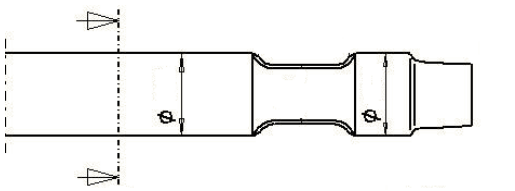
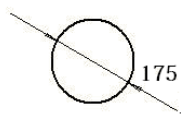
Furukawa F 22		1200	114
Furukawa F 35		1420	170
Furukawa F 45		1450	215
Furukawa 15G		1000	79
Furukawa 20G		1200	118
Furukawa 30G		1300	157
Furukawa 40G		1300	180

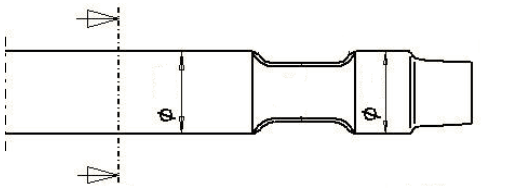
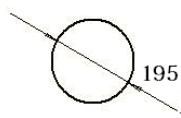
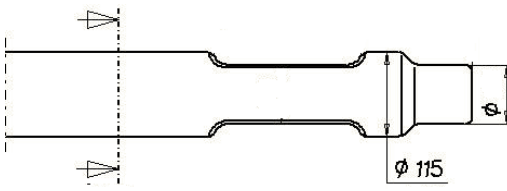
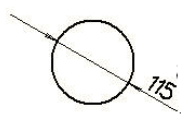
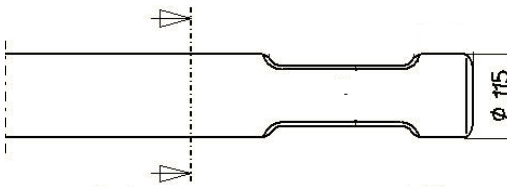
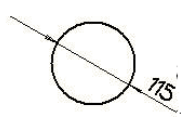
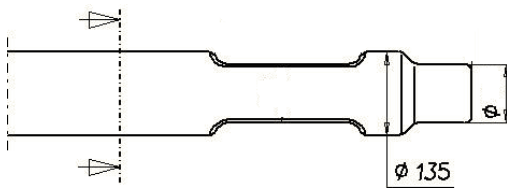
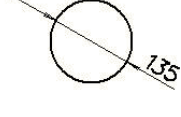
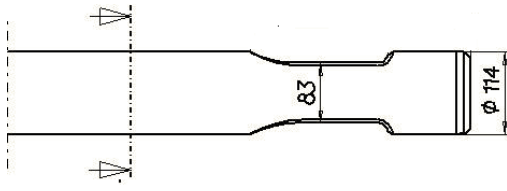

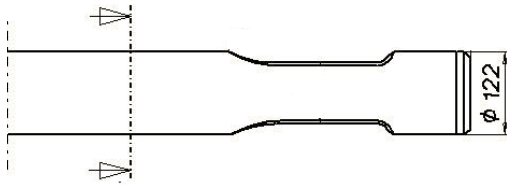
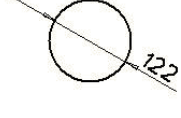
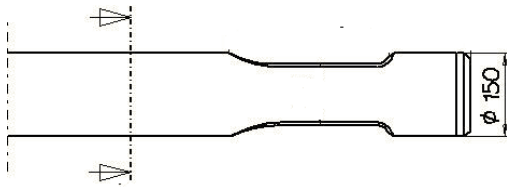
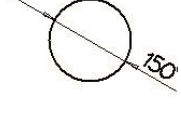
Indeco HP 1200		800	33
Indeco HP 1500			
Indeco HP 2000			
Indeco HP 3000			
Indeco MES 1500		1000	66
Indeco MES 2000		1100	84
Indeco MES 2500		1130	105

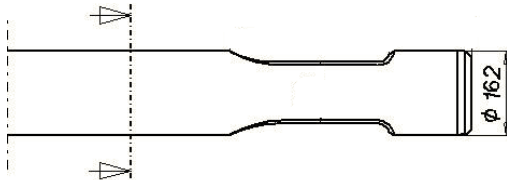
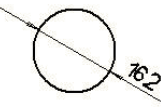
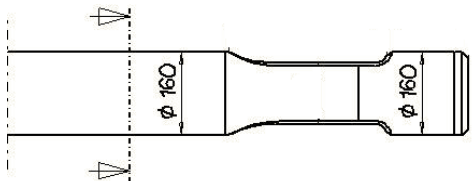
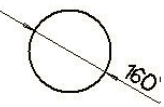
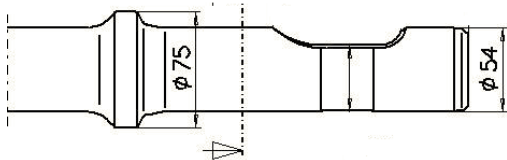
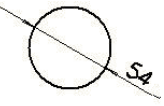
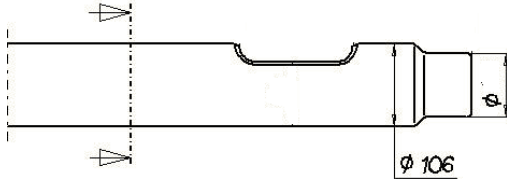
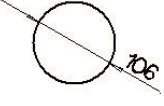
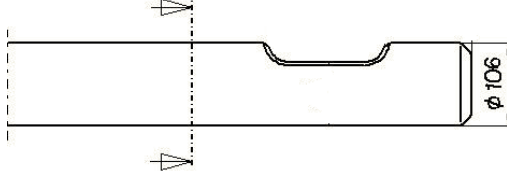
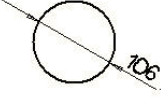
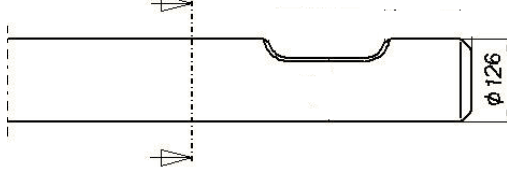
Indeco MES 3000			1200	127
Komac KB 200			600	10
Komac KB 250			600	11
Komac KB 350			820	26
Komac KB 1000			1000	52
Komac KB1500			1000	79
Komac KB 2000			1200	118

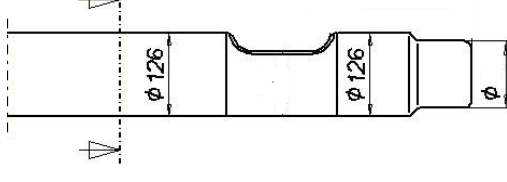
<p>Komac KB 3600</p>			<p>1300</p>	<p>157</p>
<p>Komac KB 4200</p>			<p>1450</p>	<p>189</p>
<p>Komac Tor 13</p>			<p>1000</p>	<p>55</p>
<p>Komac Tor 23</p>			<p>1150</p>	<p>97</p>
<p>Komac Tor 36</p>			<p>1300</p>	<p>145</p>
<p>Komac Tor 42</p>			<p>1450</p>	<p>189</p>
<p>Komac Tor 55</p>				

<p>Komac Tor 70</p>				
<p>Krupp HM 700</p>			<p>1100</p>	<p>78</p>
<p>Krupp HM 720</p>			<p>1060</p>	<p>76</p>
<p>Krupp HM 800</p>			<p>100</p>	<p>114</p>
<p>Montabert BRH 501</p>			<p>1000</p>	<p>70</p>
<p>Montabert BRV 32 V 1200</p>			<p>1100</p>	<p>89</p>
<p>Montabert BRV 43 V 43</p>			<p>1300</p>	<p>159</p>

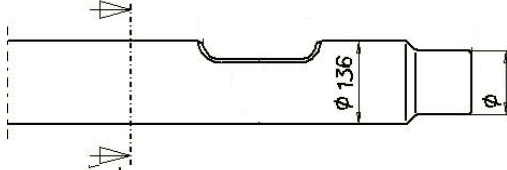
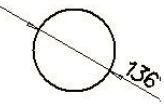
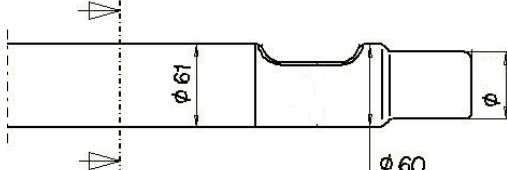
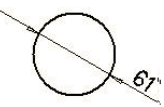
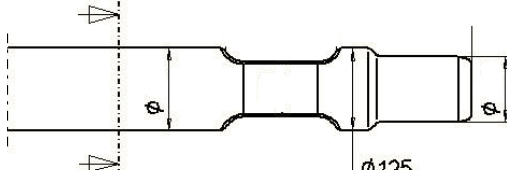
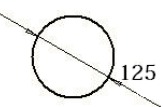
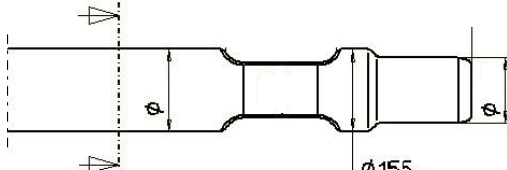
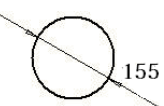
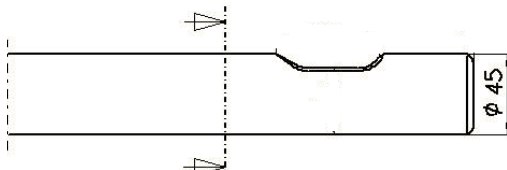
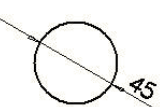
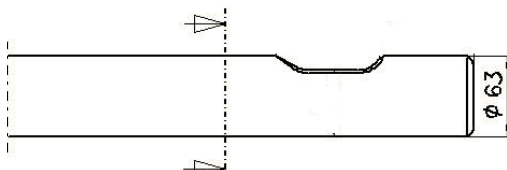
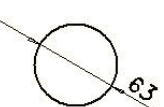
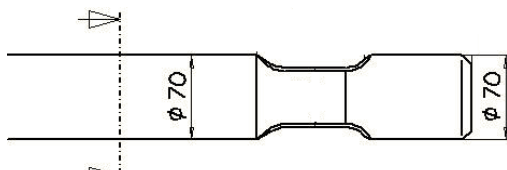
<p>Montabert BRV 52</p>			<p>1350</p>	<p>192</p>
<p>Montabert V 2500</p>			<p>1500</p>	<p>220</p>
<p>Montabert SC 16</p>			<p>540</p>	<p>9</p>
<p>NPK H 7X</p>			<p>930</p>	<p>57</p>
<p>NPK H8X</p>			<p>930</p>	<p>58</p>
<p>NPK 10X</p>			<p>1100</p>	<p>85</p>
<p>NPK 10X E</p>			<p>1100</p>	<p>93</p>

<p>NPK 12X</p>			<p>1200</p>	<p>115</p>
<p>Okada Top 35</p>				
<p>Okada Top 200</p>				
<p>Okada Top 300</p>				
<p>Rammer S 21 Sandvik BR321</p>			<p>480</p>	<p>6</p>
<p>Rammer S 23 Sandvik BR623</p>			<p>700</p>	<p>16</p>
<p>Rammer S 25 Sandvik BR825</p>			<p>740</p>	<p>20</p>

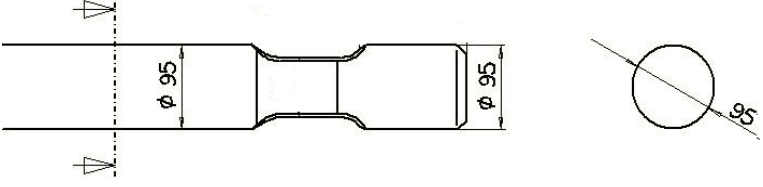
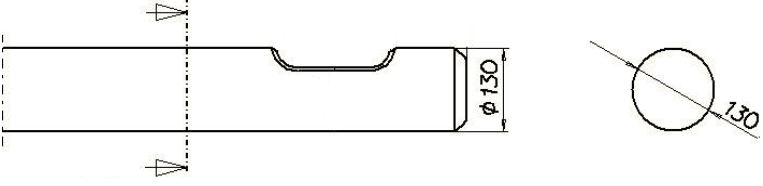
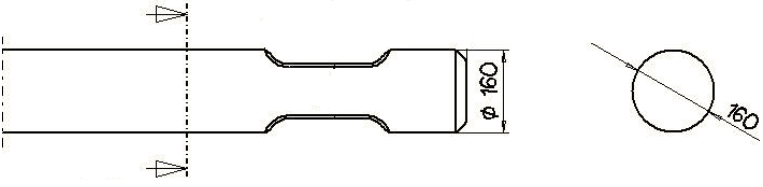
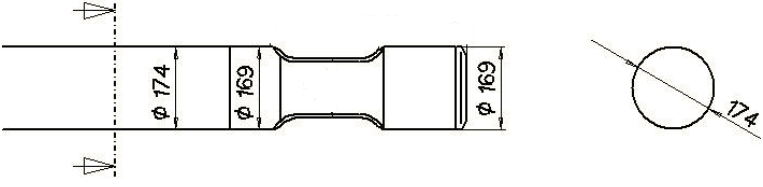
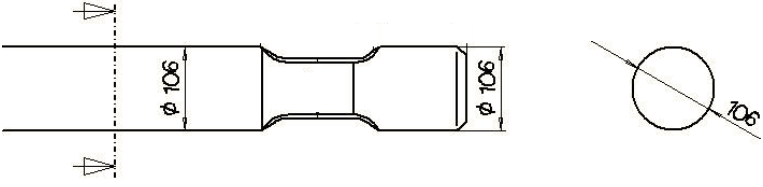
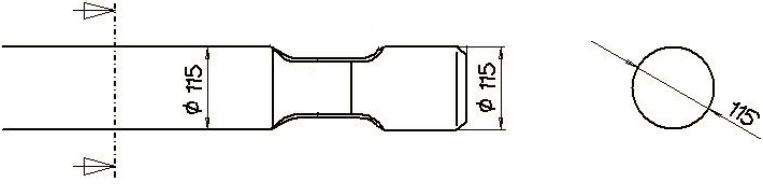
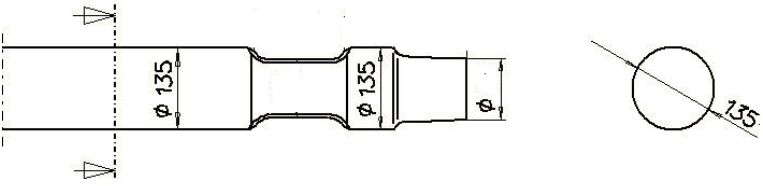
<p>Rammer S 29 Sandvik BR1229</p>		<p>900</p>	<p>45</p>
<p>Rammer S 56</p>		<p>1100</p>	<p>103</p>
<p>Rammer S 84</p>		<p>1300</p>	<p>183</p>
<p>Rammer G 110</p>		<p>1450</p>	<p>247</p>
<p>Rammer E64 Sandvik BR2064</p>		<p>1050</p>	<p>65</p>
<p>Rammer E66 / S55 Sandvik BR2266</p>		<p>1060</p>	<p>77</p>
<p>Soosan SB 70</p>			

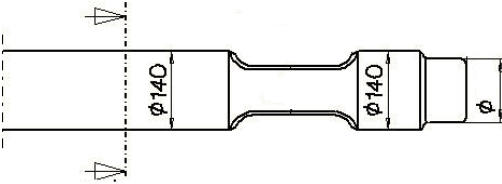
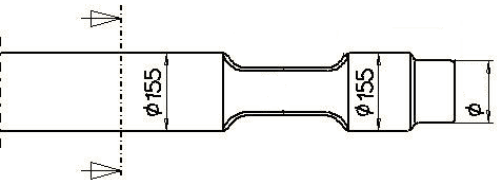
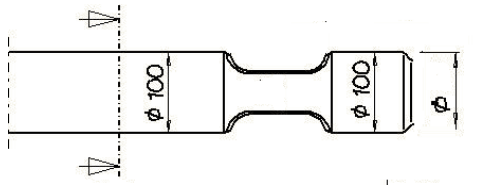
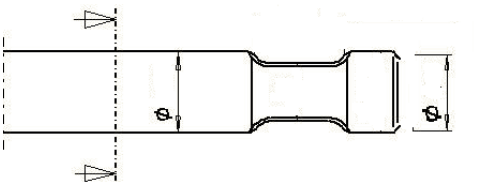
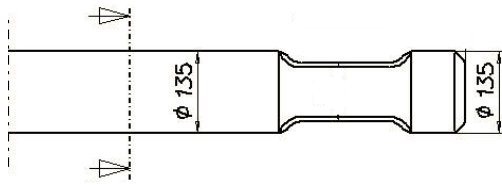
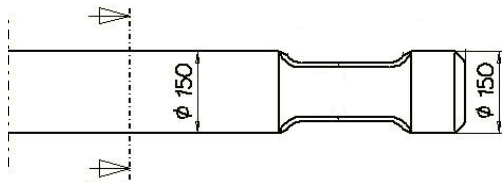
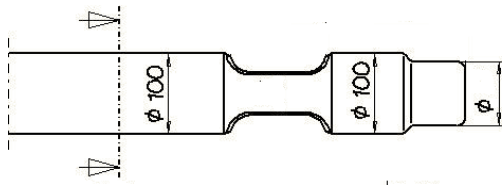

Soosan SB 81		1270	131
Soosan SB 121		1450	190
Stanley MBX138			
Stanley MBX208			
Stanley MBX258		1200	118
Stanley MBX358		1300	157
Torpedo TP 100		1000	52

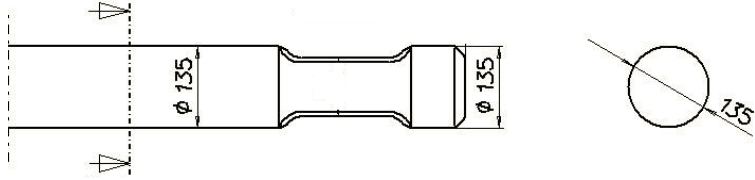
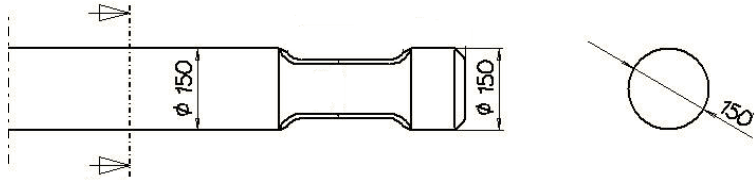
<p>Torpedo TP 200</p>		<p>1200</p>	<p>118</p>
<p>Torpedo TP 350</p>		<p>1300</p>	<p>157</p>



**SERHIDRA S.A.S**  
Minería y Construcción

[www.serhidra.com](http://www.serhidra.com)

### Contáctanos



**Dirección:**  
Parque empresarial Santo Domingo Manzana B  
Bodega 17 Mosquera – Cundinamarca



**Celular:**  
315 356 22 62 - 318 291 74 77



**Correo:**  
administracion@serhidra.com